



Electrical Components For Safety and Reliability

Quality through Experience

Since 1992, Hertford Controls has been the source of supply for high quality electrical components, used in arduous conditions and safety related applications. Our depth of experience and commitment to customer support has developed a high volume business, mostly in DC switching components for the UK mass transit industry.

Working within the bounds of our ISO 9001 approval, we have a solid reputation for quality products delivered on time. Our warehouse facility ensures that stock is available in quantity and this, coupled with a dedicated assembly area enables us to respond quickly to new demands or amended orders.

Apart from our standard ranges of switches, contactors and connectors, we have the capability to adapt these components or integrate them into our clients' equipment.

We are approved suppliers to the largest train operating companies and multinational vehicle manufacturers through to individual equipment manufacturers. Whatever the size or activity, our clients receive a fast and competent level of support from our dedicated sales team.

Quality Policy

Hertford Controls provide components and control equipment to a variety of industries. In doing so the company has gained a dual reputation; reliability of service, and the provision of components that are recognised as being dependable in safety critical environments, and having a long operational life. The benefits to our customers are the virtual elimination of rejects and the ability to respond rapidly and competently to the technical and commercial requirements of our customers. Reflecting this approach, our quality policy is 'the right goods at the right time'; our overriding goal is customer satisfaction.

This success is gained through a commitment

1. to practice continual improvement in our business;
2. to maintain approval to BS EN ISO 9001 : 2000;
3. to meet all relevant legislative and regulatory requirements;
4. to set measurable objectives and targets;
5. to train our staff to work competently;



Hertford Controls is the sales partner and licensed distributor for Schaltbau GmbH of Munich and Pintsch Bamag GmbH of Dinslaken.

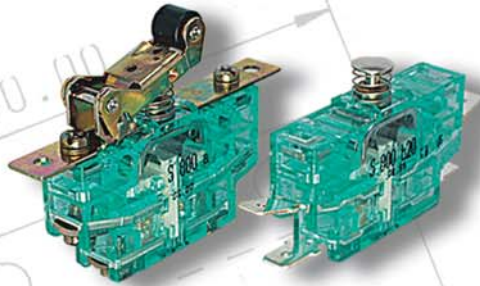

1) S800 Snap Action Switch

- Slim, fast action switch
- 10 million mechanical operations
- Failsafe mechanism
- Excellent arc dissipation
- Permanent current 10 A

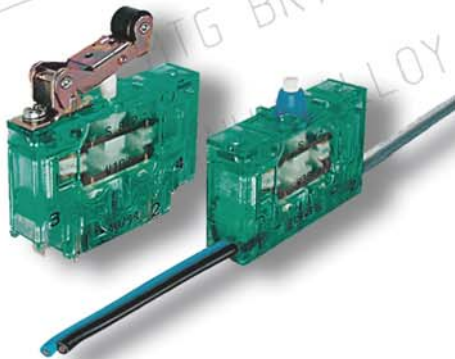

3) S847 Snap Action Switch

- Failsafe mechanism
- Sealing option to IP67
- Precise actuation at very low speeds
- Self cleaning contacts
- Transparent case



5) S804b Compact Switch

- For side mounting
- 4 terminals on front face
- Failsafe action
- Compact version of S800

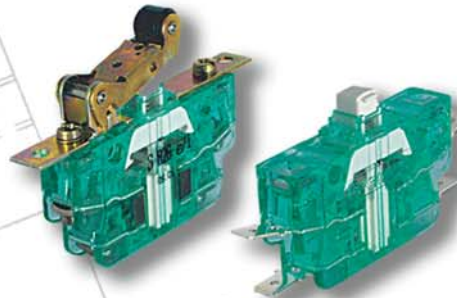

2) S826 Snap Action Switch

- Interchangeable with S800
- Self cleaning contacts
- Rating - low level to 10A permanent
- Failsafe mechanism
- Galvanically separate contacts

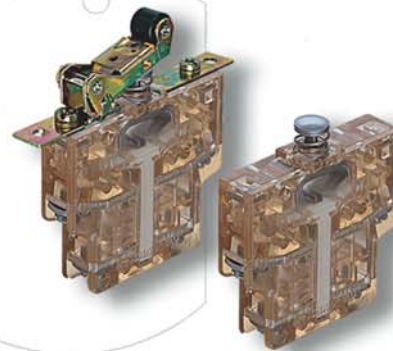

4) S820 Snap Action Switch

- Permanent current 20A
- Failsafe mechanism
- High shock/vibration resistance
- Galvanically separate contacts
- Transparent case



6) S814b Compact Switch

- Series actuation possible
- For side mounting
- Right angle operation possible
- Rating - low level to 10A permanent

Switching Devices



1) S870 Snap Action Switch

- V3 Format
- Transparent case
- Failsafe mechanism
- Sealing options to IP67
- Self cleaning contacts

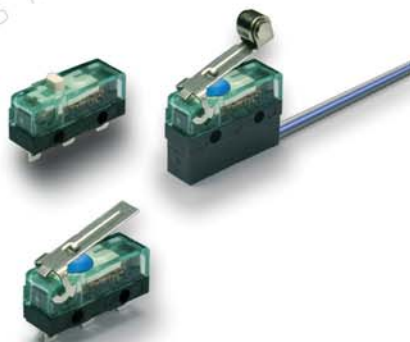

2) S880 Snap Action Switch

- V4 Format
- Failsafe mechanism
- Transparent case
- Self cleaning contacts



3) S005/S007/S008 Cam Switches

- Thermal currents up to 60 A
- High DC switching capacity
- Single hole mounting
- Ideal for cam arrays
- Bifurcated low-load option



4) S834 Enabling Switch

- For robotics and handling
- Miniature design
- Accurate operation
- Long life



5) S306/S307 Cam Switches

- Cam operated contact element
- High DC breaking capacity
- Double break contacts
- Permanent currents to 300A
- Excellent arc dissipation



6) HCP Illuminated Pushbutton Switches

- Panel sealing IP65
- Filament or LED light source
- Long operational life
- Ratings - low level to 10A permanent
- Failsafe contacts



7) Encased Limit Switch S3011 - S3222

- S804 or S814 inside
- Rugged Zinc die-cast housing
- Protective earth termination inside
- Sealed to IP66
- Connector or cable gland entry



9) Toggle Switch Series P

- Rugged design
- Many switching permutations
- Various lever designs
- Utilises S800 or S826 switching elements
- Action independent of lever speed

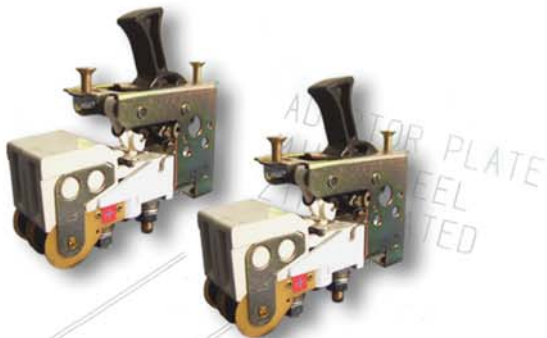

11) Toggle Switch Series L

- Continuous current ratings to 60 Amps
- Rugged design
- Many switch permutations
- Utilises S005/S007/S008 switching elements
- Magnetic blowout option



8) Toggle Switch Series F

- Utilises S870 or S826 snap action switches
- Rugged construction
- Long operational life
- Many switching permutations
- Momentary or maintained

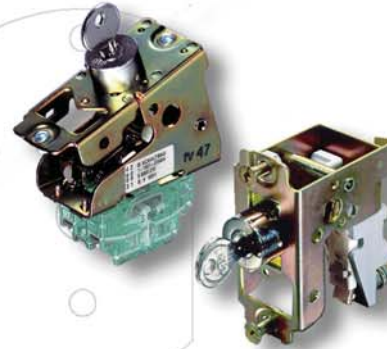

10) Key Operated Switch S126

- Electrical interlocking switches
- Protects against unauthorised use
- Single or double pole
- Utilises S800/S005/S007/S008 switches
- Thermal current ratings to 60 Amps



12) Cam Switch S073

- Utilises S800/S826/S007/S008 switches
- 1 or 2 row arrangement
- Replaceable switching elements
- Many switching permutations
- High quality long life device

Contactors



1) C137, Single-pole Contactor

- Small 50 Amp contactor
- Double break contacts
- Replaceable main contacts
- Coil tolerances to railway standards



2) C193, Single-pole Contactor

- Nominal operating voltage 1000V
- Thermal current 40 - 50A
- Compact design
- DIN rail mounting



3) C195S, Single-pole Contactor

- Compact design
- Double-break contacts
- Design with blowout
- High-voltage versions available, also for AC
- Thermal current ratings: NO 250 A, NC 160 A



4) C195A, Single-pole Contactor

- Thermal current rating 250A
- Rated insulation voltage 1000A
- Arc extinction by blowout magnets
- Double break contacts



5) C295, Double-pole Contactor

- Compact design
- Double pole, 120A thermal ratings
- Rated 1000V up to 120 A per contact
- Arc extinction by blowout magnets



6) C400/C600, Single-pole Contactor

- Compact design
- Available with one or two auxiliary switching elements, series S870
- Single-pole NO contactor for 400 A DC or for 600 A DC as deep discharge protection for batteries in emergency installations



7) C294, Double-Pole Contactor

- Nominal operating voltage 1000V
- Thermal current 40A
- Compact design
- Optional terminal guard



8) C162, Single-pole Cam Contactor

- Rugged, compact construction
- Thermal current 250A
- Various combinations of 8 auxiliary switches
- Rated insulation voltage 1000V



9) C152, Multi-pole Cam Contactor

- Rugged construction
- Various combinations of switching elements
- Easily replaced contact sets
- Coil economy option
- Parallel connection: 800 A max



10) C155, Multi-pole Contactor

- Rugged construction
- Thermal current rating up to 300A
- Rated insulation voltage 1000V
- Coil economy circuit option
- Easily replaced contacts and arc chambers



11) CX Power Contactor

- Single pole, normally open contacts
- High breaking capacity
- AC/DC currents to 800A, 1500V

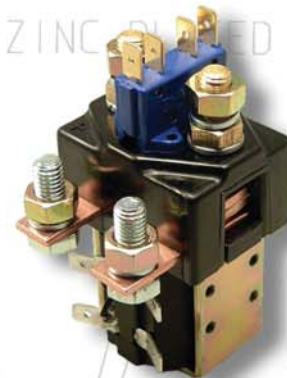

12) AFS Contactors

- Viable alternative to comparable industry standard
- Competitively priced
- Short run flexibility
- Readily available
- Low cost replacement parts

Connectors



1) NF Series Connector

- 7 or 10 way miniature audio connector
- Bayonet locking
- Self cleaning, butt contacts
- IP68 sealed even when uncoupled
- Shielding 70dB (10KHZ to 10 MHZ)



2) GM Series Connector

- Rugged PA housing
- Modular design
- Sealed to IP67
- Current rating to 100A
- Contact arrangement to 64 way



3) GA Series Connector

- Sealed to IP67 even when uncoupled
- Current rating 50A/10A
- Resistant to aggressive liquids
- Aluminium housing with positive thread locking



4) EP Series Connector

- Connector for power and signal transfer
- Application: Bypass of an electro-pneumatic emergency brake
- UIC 541-5-VE
- Impact resistant metal handle
- Main contacts 110V / 50A
- 10,000 cycles



5) G Series Connector

- Die cast aluminium housing
- Current rating to 100A
- Bayonet connection
- Contact arrangement to 48 way
- Receptacle hinge cover version



6) M Series Connector

- Sealed to IP67
- Modular design
- Halogen free PA housing
- High quality crimp/solder contacts
- Current ratings to 50A



7) UIC 558 Series Connector

- Increased resistance to chemical influences
- 18 Pole receptacle matable with 13 pole plug
- Rated current 10A to 63A / RF 1.5A
- UIC 558 standard intercoach jumper connector
- Snatch release system



9) LB Series Charging Connector

- High impact resistance
- 2 Pilot contacts can be retrofitted
- Battery fluid-tightness
- No special tool needed for assembly
- Charging connector with or without air passage: Dimensions to DIN 43589-1; approved to EN 1175 - 1



11) R Series Connector

- Resilient contact carriers
- For extreme shock and vibration
- 12 contacts - 16A / 120 A
- Locking by means of M10 screws



8) LV Series Charging Connector

- Increased current capacity
- Innovative socket contact design
- Constant contact force over time
- Reduced temperature rise
- Improved resistance to acids and temperature

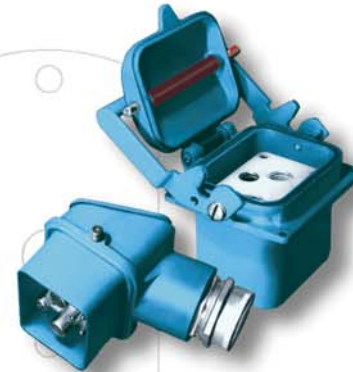

10) B Series Connector

- Rugged design for intercoach connection
- Range of contact arrangements to 59 way
- Rated currents 20mA to 400 A
- Interlocking facility



12) UIC 552 Series Connector

- UIC 552 Single pole connector
- Rated current 800A
- Rated voltage 3KV AC/DC
- Contact for 185mm² wire gauge



1) Disconnecting and Earthing Device

- Conforms to applicable safety regulations
- Suitable for all UIC voltages
- Insulation for operating voltages to 5KVDC
- Multiplicity of mounting positions
- Max break capacity 5KVDC/50A



2) Flat Battery Power Supply

- Ensures control voltage independent of batteries
- No unplanned maintenance costs
- Eliminates backup battery costs
- Insulation for operating voltages to 5KV DC



3) High Voltage Fuses

- Suitable for all UIC voltages
- Approved by European railway authorities
- Rated voltages to 1KV - 5KV
- Rated currents 2A - 125A



4) DC/DC Converter ZH904

- Designed for use under particularly harsh environmental conditions
- Approved by many European rail authorities
- High output performance from a compact design
- Various versions available
- Several converters can operate in parallel



5) Overtemperature Protection Device

- Protection for high voltage heaters
- Independent of control voltage
- Independent of electronic regulation devices
- Replaceable Fusible link
- Optional auxiliary switch

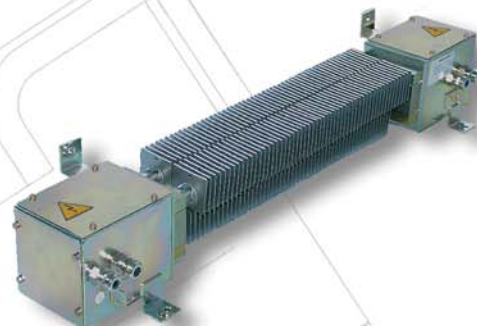

6) High Voltage Heaters

- Suitable for all UIC voltages
- 1800V, 600W
- Stainless steel housings
- Customised designs possible

1) Emergency Disconnect Switch S132, S134

- Opens power circuits quickly and effectively in emergency
- Magnetic blowout
- Thermal currents 125A / 250A
- Cylinder lock available
- Auxiliary contact available

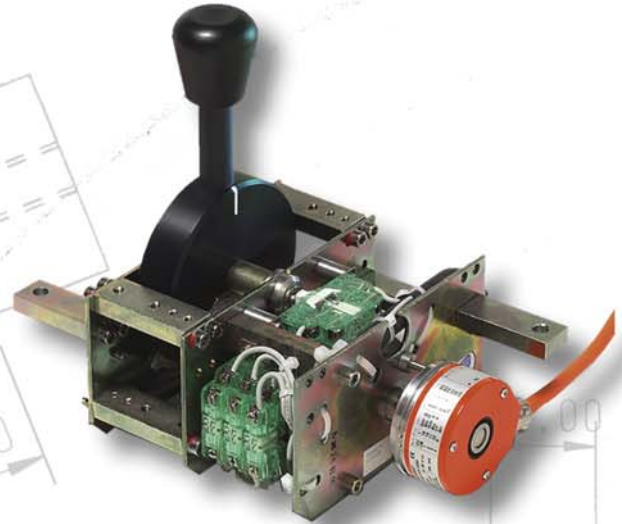

2) Master Controllers

- Modular design principle: ergonomic design options
- Functional reliability ensured by high resistance to shock and vibration
- High quality standard ensured by product testing and improvements
- Control switches, master and brake controllers manufactured to the customer's specifications
- Other applications, eg. crane construction and shipbuilding

3) Emergency Disconnect Switch S135/1

- Opens power circuits quickly and effectively in emergency
- Magnetic blowout
- Thermal currents 160 - 250A
- Easily replaced contacts
- Single pole or double pole



4) Emergency Push Button

- All metal actuator
- Recessed push button
- Twist release
- Easily replaced contacts
- Two pole, NO + NC contacts
- Thermal currents to 10 Amps

5) Passenger Emergency Pull Device

- Aesthetically pleasing design
- Easily operated
- Key resetable
- May be sealed with a lead tab



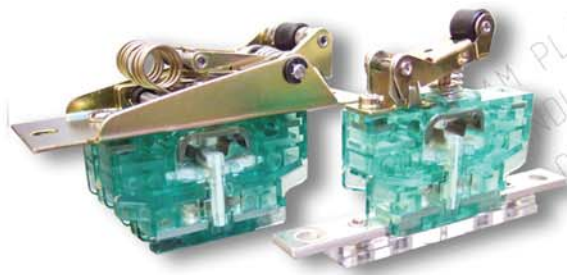

1) Customised Switches

- Specialised actuators
- Mounting adaptations
- Non-standard terminal styles
- Designs in accordance with customer drawings
- Increased levels of testing and selection for specialised purposes



3) Variants to standard switches

- Base switches and ancillary parts held in bulk stock
- Special springs, terminals, actuators, magnets etc
- Switch variants available without lengthy lead times
- Modifications or enhancements can be quickly carried out
- Impact of minimum selling quantities reduced



2) Cable Assemblies

- Wired connector assemblies to customer specifications
- Continuity and ingress testing available
- Renovation, repair and replacement of damaged or life expired assemblies
- High quality work at reasonable cost

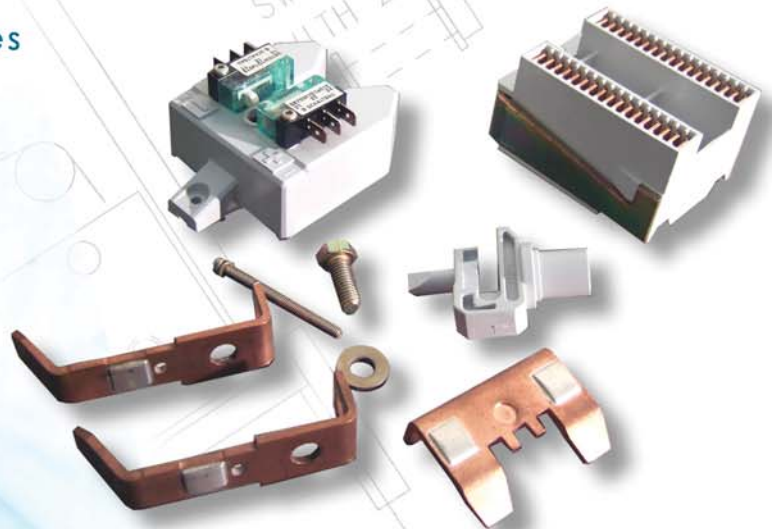

4) Spare Parts for Contactors

- Contact tips, cases, coil assemblies
- Manuals and parts lists
- Retrofit of auxiliary switches